

# bigrep ONE

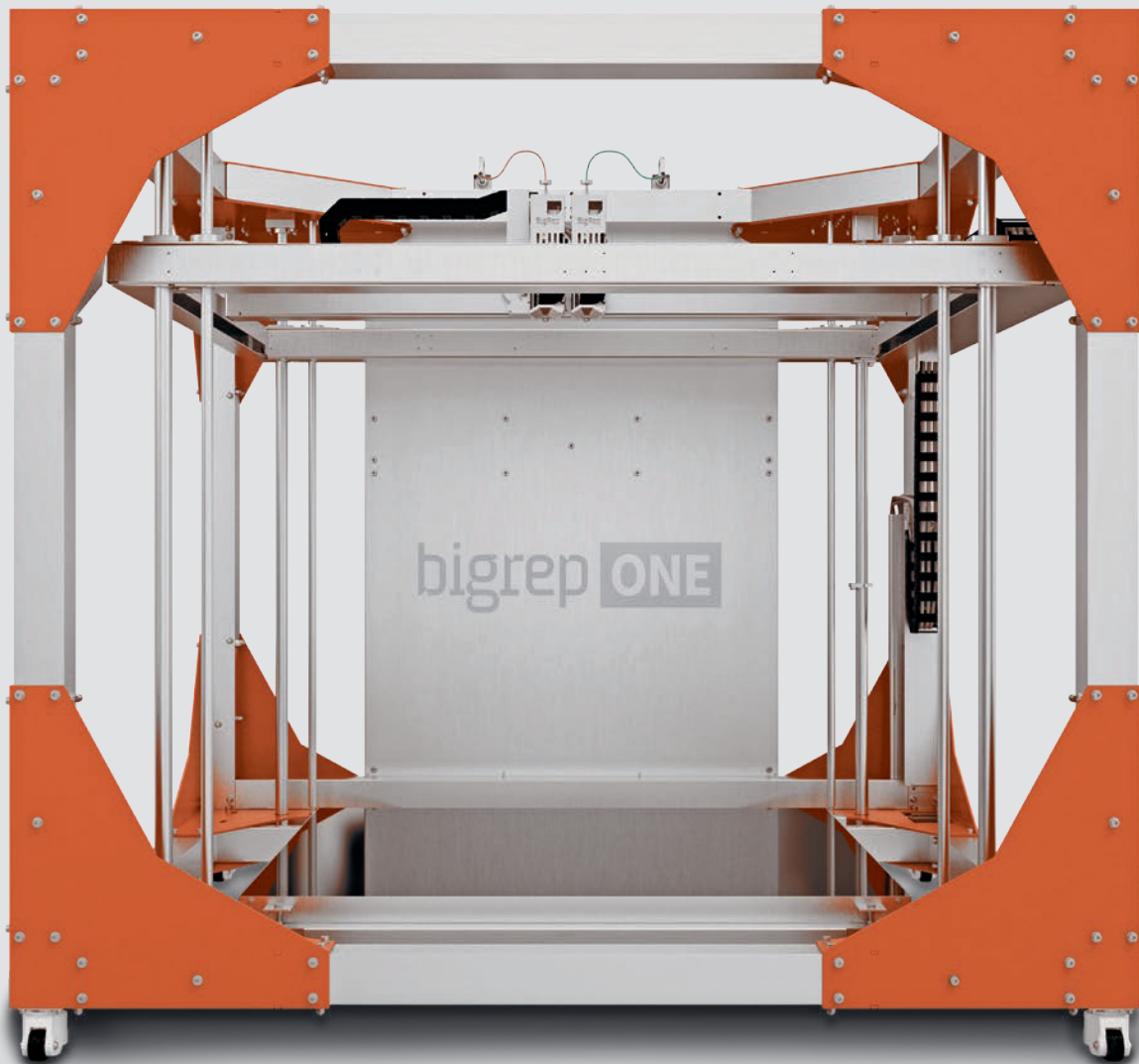

## THE MOST ADVANCED **LARGE-SCALE** **3D PRINTING** EXPERIENCE

The large-scale FFF 3D printer for  
professional and industrial use.

## AWARD-WINNING INDUSTRIAL DESIGN FOR **BIG IDEAS**

The driving force behind the BigRep ONE v3 remains unchanged: to make large-scale 3D printing affordable and available to more users.

To achieve the best possible conditions for printing large objects, many new features have been introduced. Despite its open format, all moving parts are safely enclosed. For additional safety, an optional plexi glass door is available on request.

The large print bed has been further improved allowing for even better calibration. For large-scale prints, our new Power Extruder for 0.6 mm, 1 mm and 2 mm nozzles allows for high-speed printing without compromising on print quality.

With the new BigRep ONE v3 we have made affordable, large-scale 3D printing even better – as acknowledged by the German Design Award 2016 we recently received.





m<sup>3</sup> VOLUME

# UNCOMPROMISING GERMAN ENGINEERING — THE NEW **BIGREP ONE**

The BigRep ONE v3 was developed to make 3D printing of large-scale objects as easy as possible. Every detail has received our full expertise and experience — for better quality, higher speed and increased safety.

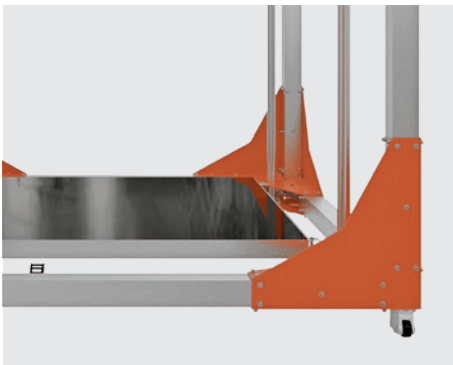

## **Open and Safe**

### The Frame Construction

The open format ensures that the user has the best possible view for monitoring the quality and progress of the object at all times. Moving parts have been enclosed for user safety, aided by integrated sensors that ensure precision and user friendliness.

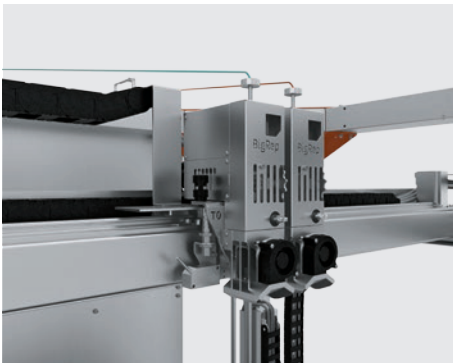

## **Modular and Independent**

### The Extruders

The modular print heads operate independently, allowing for unbeatable flexibility when printing in two colors or with a different support material (break-away or soluble). They can be easily adjusted and replaced without the need for tools. During the printing process, the inactive print head moves upwards slightly to avoid making contact with the object. The print heads were developed by BigRep's in-house team and optimized for large-scale printing projects.

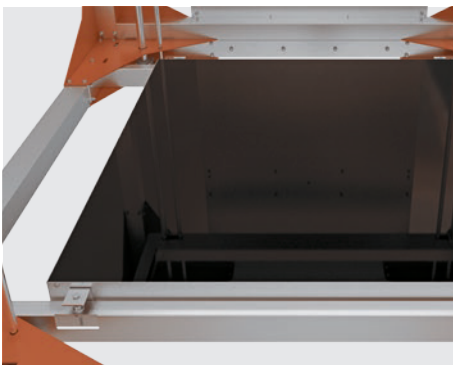

## **Semi-automatic print bed levelling**

### The Print Bed

The heated print bed mounted with PI provides optimal adhesion in the printing process right from the outset. Thanks to an integrated automatic inductive sensor, the print bed can be leveled quickly and effortlessly, reducing prep time considerably.

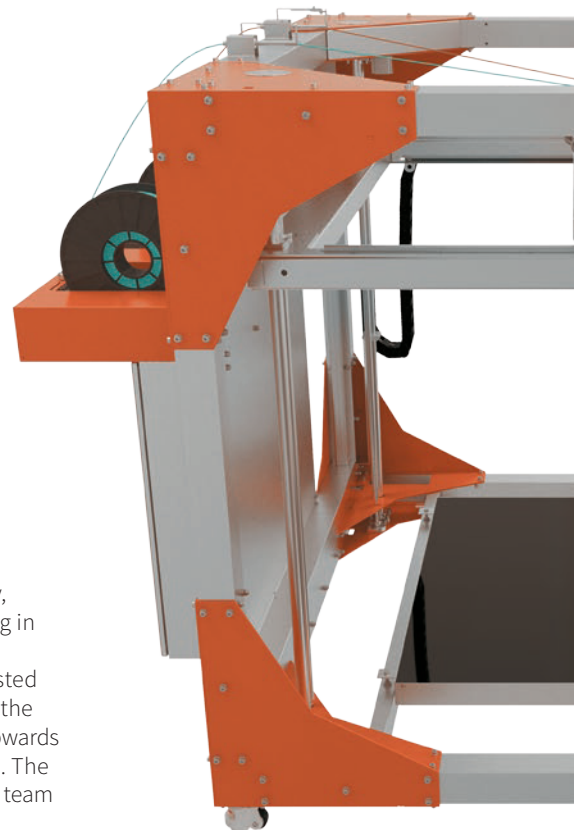



The BigRep ONE v3 – the largest serially produced FFF 3D printer.

## Big, Bigger, the Biggest The Build Volume

The new BigRep ONE v3 features a build volume of X 1005 mm x Y 1005 mm x Z 1005 mm. With a capacity of over one cubic meter, the new BigRep ONE v3 provides the largest serially produced FFF 3D printer currently available on the international market.



## Spacious and Flexible The Spool Holder

The spool holder has been designed to fit all standard spool sizes. It can hold several spool of up to 8 kg. A run-out detection system notifies the user when the pool is about to end. Optionally a filament enclosure box is available to protect filament from dust and moisture.



## Easy and Intuitive The Graphical User Interface

The new intuitive user interface on touch panel PC enables many new features, such as remote load, check print progress via webcam, resume print after power failure, and many more.



# COST-EFFICIENT TECHNOLOGY FOR A BROAD RANGE OF **APPLICATIONS**

The BigRep ONE v3 sets new standards and offers a broad range of applications for large-scale 3D printing projects. It is easy to use and can be employed virtually anywhere, allowing for quick and cost-efficient manufacturing of prototypes, molds and final products.

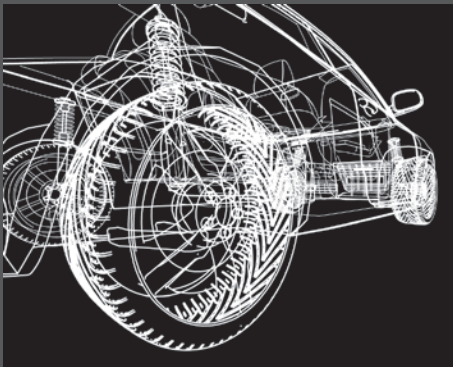

## ENGINEERING AND RAPID PROTOTYPING

Being able to produce prototypes quickly and cost-efficiently opens up new development and design possibilities for industrial users. With the BigRep ONE v3 large numbers of iterations can be simply manufactured without incurring high costs. This means better products and shorter development times.

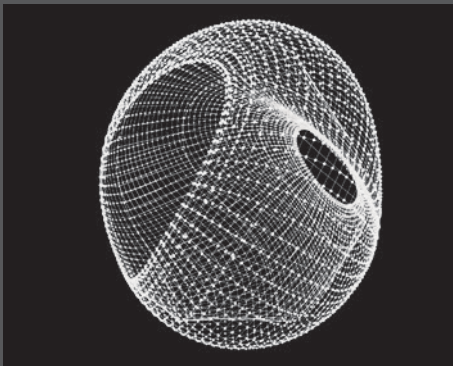

## RESEARCH AND DEVELOPMENT

With the BigRep ONE v3 we provide a tool that offers new possibilities for teaching and research to students, teachers and scientists alike. The machine is easy to use, and its open format enables numerous users to observe and experiment with additive manufacturing processes while gaining experience in the production of large-scale objects.

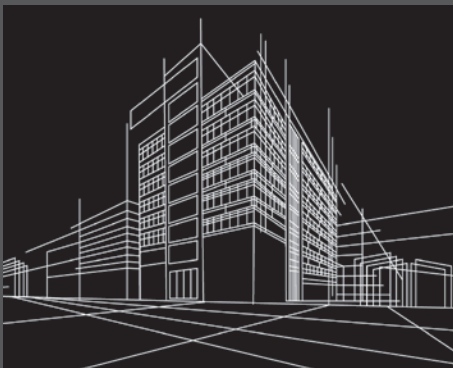

## ART, DESIGN AND ARCHITECTURE

The BigRep ONE v3 is a tool that opens up previously inconceivable opportunities to designers, artists and architects. The BigRep ONE v3 can be installed virtually anywhere and put into operation after brief familiarization. Creative professionals can now produce large objects in their own studios and workshops. Thanks to this cost-efficient technology, trying out various designs quickly and effortlessly is no problem. Even final products of up to one cubic meter in size can be manufactured with the BigRep ONE.

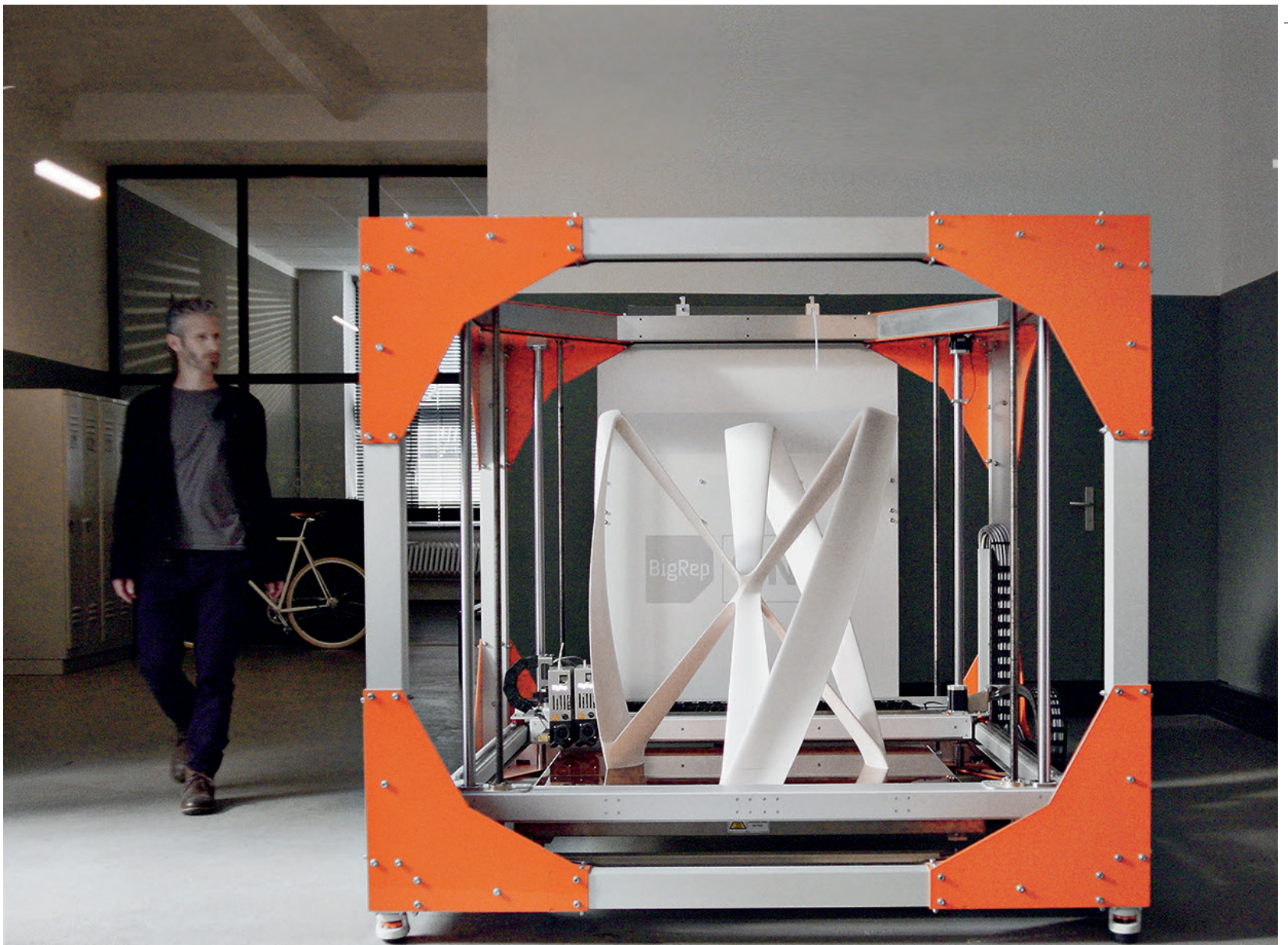

The new BigRep ONE v3 was created for a range of applications: from industrial rapid prototyping to ready-to-go design products – anything is possible. It provides you with affordable and easy-to-use technology for large objects and ideas. **Smart solutions for big prints.**

# REFINE BIG PRINTS WITH **POST-PROCESSING**

Sometimes a 3D print serves as a blank. Objects printed with FFF can be treated and refined in various ways, for example by improving or modifying their surfaces, or by using objects as positive or negative forms for molding and casting processes.

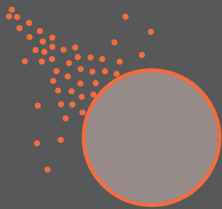

## SMOOTHING AND FINISHING

Grinding, sandblasting, shot blasting and vapor steaming are the most common methods of finishing FFF 3D-printed objects. These enable the creation of prototypes which adequately convey the final product's look and feel.

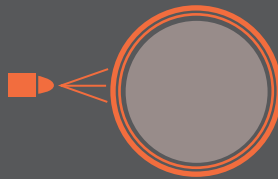

## COATING

Various coating methods help create true-to-form design prototypes out of 3D-printed objects. Coatings can also improve functional characteristics such as strength, temperature resistance and adhesiveness.

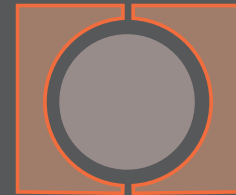

## MOLDING AND CASTING

3D printing, and especially large-scale 3D printing, is an ideal tool for manufacturing positives for molds and casts. Injection molding, silicone molding and composite molding are the most commonly used techniques.



Effective and successful finishes require high-quality 3D prints. The BigRep ONE v3 modular print heads were developed from scratch by our in-house team and can be controlled independently. You can also vary the print speed and amount of material extruded by each print head during the printing process, thereby ensuring a clean dual-extrusion or multi-material print.



THE **BIGREP ONE** IS  
A PERFECT **STARTING POINT**  
FOR THE **FACTORY OF THE FUTURE**

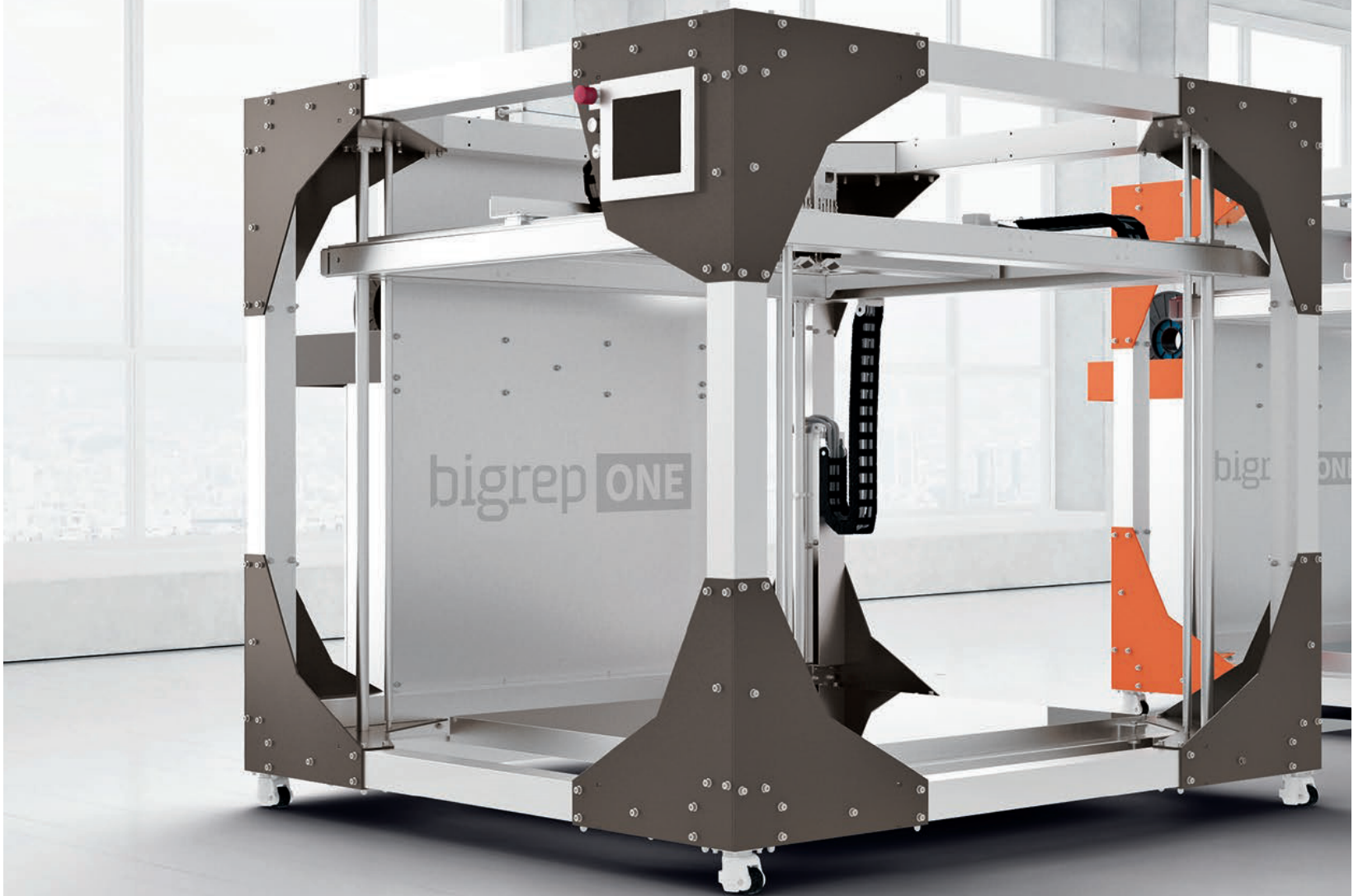



For simultaneous use, several BigRep ONE v3 3D printers can be operated concurrently in what is referred to as a printer farm. Splitting print jobs among several machines increases efficiency, variability and speed. You can also connect the BigRep ONE v3 to 3D print processing software in the same way.

# TECHNICAL SPECIFICATIONS

With a build volume of more than one cubic meter, the BigRep ONE v3 was designed and constructed for countless printing hours, consistent quality, and optimal results.

Build volume	<b>x 1005 y 1005 z 1005 (mm)</b>
Layer resolution	<b>400 – 900 microns</b>
Acceleration	<b>Up to 400 mm/s<sup>2</sup></b>
Extruder	<b>Two modular extrusion heads</b> Standard Extruder for 1 mm nozzle High Power Extruder with 0.6 mm, 1 mm and 2 mm nozzles (option)
Printing technology	<b>FFF – Fused-Filament-Fabrication (FDM)</b>
Certified materials	<b>BigRep PLA, BigRep Pro HT, BigRep PETG, BigRep Pro HS</b> other filaments on request.
Support materials	<b>BigRep PVA</b>
Print bed temperature	<b>Max. 80 °C</b>
Printer weight	<b>Approx. 460 kg</b>
Size	<b>x 1850 y 2250 z 1725 (mm)</b>
Power	<b>208 V – 240 V, 16 A, 50/60 Hz</b>
Safety certifications	<b>CE approved</b>



## FILAMENT

BigRep offers filaments designed especially for large-scale printing with the BigRep ONE. These filaments are manufactured under carefully controlled conditions to ensure a consistent diameter and thus consistent and precise construction of objects.

BigRep's filaments are made according to open-source designs, meaning there is no vendor lock-in for customers.



## BIG PRINTS

From experiments to complete furniture, from individual parts to objects composed of multiple materials, from the initial idea to the final product – anything is possible.



## SMART SOLUTIONS FOR **BIG IDEAS**

### **bigrep.com**

EUROPE  
Gneisenaustraße 66  
10961 Berlin  
Germany  
Phone +49 30 20 84 82 60

AMERICAS  
Newlab, 19 Morris Avenue,  
Cumberland Gate  
Brooklyn, NY 11205  
United States  
Phone +1 347 622 2553

APAC  
25 International Business Park  
#04-101 German Centre  
Singapore 609916  
Phone +65 8722 3241